

### General Description

The SINADDER\* is a specialized distortion meter for making SINAD measurements on radio receivers. Special circuit design speeds and simplifies the SINAD measurement by eliminating all distortion meter adjustments.

The null circuits of the SINADDER are internally set to the 1,000 Hz tone used in SINAD measurements, and an automatic gain control eliminates the need for setting input gain to the meter.

The automatic gain control feature permits the SINADDER to be used as a receiver alignment tool, providing rapid alignment of receivers for optimum performance.

### Circuit Description

A block diagram of the SINADDER is given in Figure 1. The input circuits of the SINADDER are connected to the audio output circuits of the receiver being tested. The signal appearing at the input to the SINADDER consists of the wanted 1,000 cycle "Signal" frequency and other frequencies representing the noise and distortion created in the receiver. This composite Signal, Noise, and Distortion signal is amplified by two cascaded AGC

amplifiers. The output of the second AGC amplifier is a replica of the input signal, but at a constant average level, regardless of input signal level changes from 20 millivolts to 4.25 volts RMS.

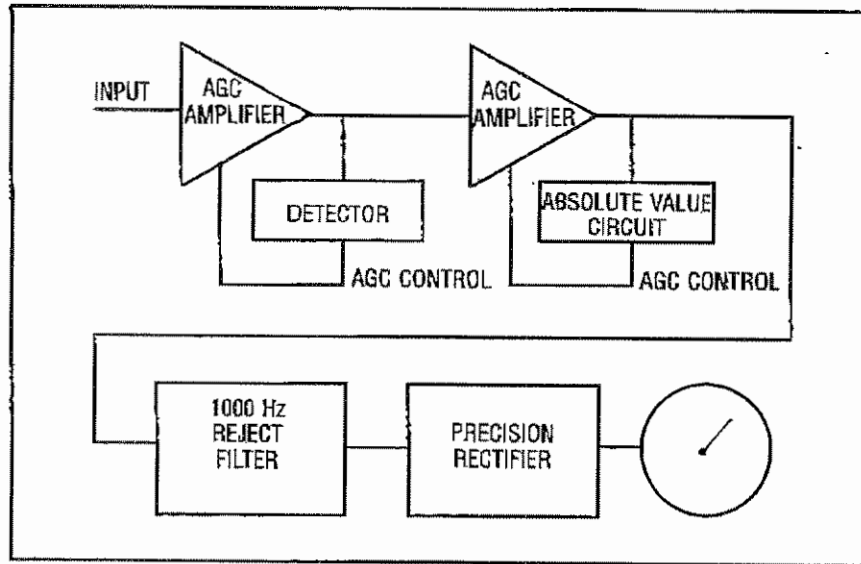

Figure 1. SINADDER™ Block Diagram

The composite constant level signal is then fed into a 1,000 cycle reject filter which removes the 1,000 cycle "Signal" component, leaving only the Noise and Distortion components. These components are amplified and rectified by a precision average value rectifier circuit and then used to drive the indicator meter. Since the input signal to the reject filter is held constant, the meter can be directly calibrated in SINAD values.

Normally, the SINADDER is connected to the loudspeaker terminals of the receiver under test. The 4.25 volts RMS maximum input will accommodate audio power levels up to 5.6 watts into a 3.2 ohm speaker. Since 4.25 volts RMS amounts to 12 volts peak-to-peak, levels greater than this voltage are not expected in radios operating from 12 volt supplies. On the low side, the 20 millivolts RMS permits the connection to be made as early in the circuit as the discriminator output. For quantitative SINAD measurements, the connection must be made after the de-emphasis circuit, but connections ahead of the de-emphasis circuit will give meaningful relative readings.

## Operating Instructions

If you are not familiar with SINAD measurements, be sure to read the section "A Few Words About SINAD Measurements" beginning on page 5.

Before using the SINADDER with a specific signal generator, check the 1,000 Hz modulating tone of the generator to be certain it is accurate enough to fall in the center of the SINADDER's null circuit. If the generator makes the modulating signal available on an output jack, simply connect it to the SINADDER test leads and see if the SINADDER meter indicator goes into the black portion at the left of the scale. If the generator you are using is not close enough, it will be worthwhile to correct it. Commonly used FM monitors have very accurate 1,000 Hz sources, and you can depend upon them to be correct. Some signal generators have a front panel dial for adjusting the modulating signal frequency. If yours is this type, tune it for minimum indication on the SINADDER and mark the spot on the dial for future reference.

Now, for the SINAD measurement: Connect the leads from the SINADDER to the loudspeaker output of the receiver, with the black lead going to the speaker ground terminal. Connect the signal generator to the receiver and set its modulation and frequency as shown in Figure 2. That's all there is to it, the SINADDER is now measuring SINAD for you.

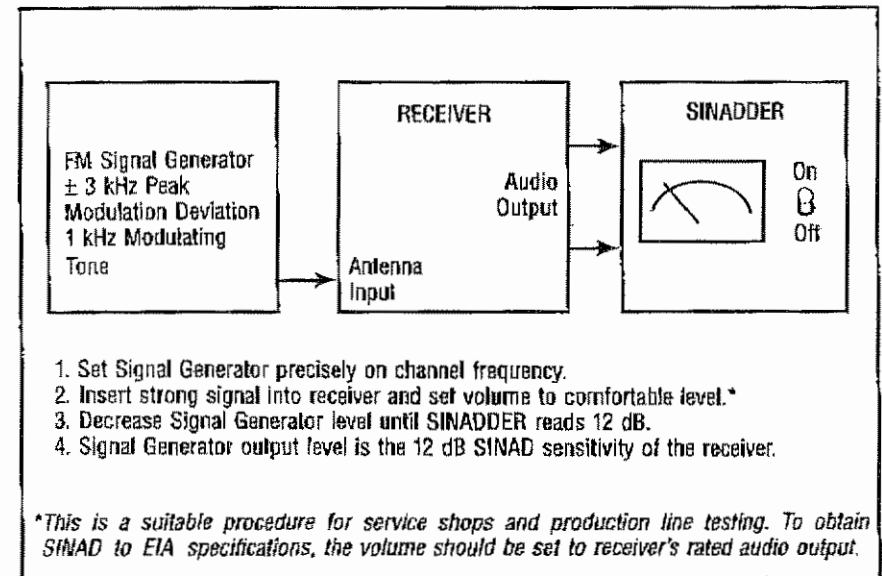

Figure 2. SINAD measurement using the SINADDER™

If you turn the signal generator up to a strong, noise-free signal, if the receiver has low distortion, and if the generator and receiver agree on channel frequency, the SINADDER meter indicator will swing into the black area at the left of the meter scale. If you remove the signal from the receiver and set the squelch control to let the set roar, the SINADDER meter indicator will swing into the black area at the right of the meter scale. To determine the 12 dB SINAD sensitivity of the receiver, adjust the signal generator output attenuator until the SINADDER indicates 12 dB. The microvolts output of the signal generator is the 12 dB SINAD sensitivity of the receiver.

### Using the SINADDER for Receiver Alignment

Now that you have measured the receiver's sensitivity with the SINADDER, don't stop there! Odds are you can improve the sensitivity a few dB just by touching up the front-end alignment adjustments, using the SINADDER as an indicator of optimum performance.

Set the signal generator level so the SINADDER reads about 12 dB. Then adjust the various front-end adjustments to make the meter swing as far to the left as you can. If you get below the 20 mark, reduce signal generator output to bring the meter reading back to about 12 dB. Even though a receiver has been accurately aligned using the traditional limiter meter methods, this touch-up of the front-end section will typically gain an improvement in sensitivity.

Ever have a receiver in the shop that seemed to need realignment, but you were afraid to try it without an instruction manual? You can do the realignment with the SINADDER. Just set the signal generator to about the 12 dB SINADDER reading and tweak away at the alignment screws. If you don't move any adjustment very far from its original setting, you won't go wrong. But watch out for sets with AFC circuits. If your realignment doesn't leave the AFC voltage properly centered, the receiver may "rest" off to one side of the channel.

Try using the SINADDER for alignment of a few receivers. Once you have gained confidence in it, you will find it is a great timesaver. Receivers will leave your bench quicker and working better.

### A Few Words About SINAD Measurements

The term SINAD is an abbreviation for the following ratio:

$$\frac{\text{Signal plus Noise And Distortion}}{\text{Noise plus Distortion}}, \text{ expressed in Decibels.}$$

The signal level at which a receiver produces a 12 dB SINAD ratio is referred to as the 12 dB SINAD sensitivity of the receiver. In practice, a 12 dB SINAD signal is a reasonably intelligible and useful signal for speech transmission.

Since a SINAD measurement gives a more meaningful measure of a receiver's useful sensitivity than is obtained by other methods, it has become the preferred method of specifying and measuring receiver sensitivity in FM receivers used in land mobile and marine services.

The exact method of measuring 12 dB SINAD sensitivity is given in the Electronic Industries Association's Standard TIA/EIA-603\*, which is quoted here:

*"A 1000 microvolt test signal from a standard input signal source with standard test modulation shall be connected to the receiver antenna input terminals. A standard output load and a distortion meter incorporating a 1000 hertz band elimination filter shall be connected to the receiver audio output terminals. The receiver volume control (low level) shall be adjusted to give rated audio output. The standard input signal level shall be reduced until the SINAD is 12 dB. At this value of signal input, the audio output shall be at least 50% of the rated audio output without readjustment of the volume control. If the audio output is less than 50% of the rated audio output, the input signal level shall be increased until 50% of full rated audio output is obtained, and this value of input signal level shall be used in specifying sensitivity.*

**Note:** *A receiver with more than one volume control shall be adjusted utilizing a control preceding the audio power amplifier."*

Standard TIA/EIA-603 specifies that the receiver shall be operated into a resistive load equivalent to the load into which the receiver normally operates. It also specifies standard test modulation as being 60% of the peak modulation used. (3 kHz peak, for typical communications systems using 5 kHz maximum peak modulation.)

Since the SINAD definition includes the distortion created by the receiver's audio output stage, a precise measurement of SINAD should be made at the rated audio output. However, in typical equipment with low distortion amplifiers, a reasonably accurate SINAD measurement can be made with the audio output merely set at a comfortable listening level, using the loudspeaker of the receiver as the audio load.

\*Reprinted by permission. Copies of TIA/EIA-603 are available from Electronic Industries Association, 2001 Eye Street, Washington, D.C.

### About Accuracy:

For a precise determination of the ratio implied by the SINAD definition, the measurement circuits of the distortion meter should measure the RMS values of the composite signal, noise, and distortion waves. However, almost all commercially available distortion meters are based upon average measuring, but RMS calibrated, metering circuits. At the low distortion and noise percentages involved in the typical 12 dB SINAD measurements, the error created by the use of average metering circuits instead of RMS metering circuits is negligible. The metering circuits of the SINADDER are average measuring in nature to provide optimum correlation with commonly used distortion meters.

The width of the null in commercial distortion meters varies considerably from one model to another. While this will not create any discrepancy in simple distortion measurements, the width of the null will affect readings on noise measurements. Therefore, perfect correlation between SINAD indications may not be obtained between different model distortion meters, although they agree perfectly on ordinary distortion measurements.

Although different model distortion meters may give slightly different SINAD readings on the same composite signal, the SINAD method of measuring receiver sensitivity is remarkably precise. This is because the 12 dB SINAD performance of a typical FM receiver falls in a place on the FM improvement curve where a small percentage change in incoming signal will create a large change in SINAD reading. Thus, distortion meters differing by two or three dB in their SINAD reading will result in 12 dB SINAD sensitivity measurements which correlate to better than 1 dB. 12 dB SINAD sensitivity measurements made with the SINADDER will correlate within 1 dB to the sensitivity measurements obtained by the use of most popular distortion meters.

### Calibration Checks:

The following procedure can be used to check the calibration of the SINADDER:

Connect the SINADDER input leads to a 2,000 Hz audio source. The SINADDER meter indicator should go to the black area to the right of the scale and should stay there as the voltage of the audio source is varied from 20 millivolts to 4.25 volts RMS. If not, adjust R45 to set the meter to the right edge of the black segment with the input signal set at about 1 volt RMS.

Connect the SINADDER input leads to a 1,000 Hz source. This source must be accurate to within 1Hz. Adjust the source to 1 volt RMS output. The SINADDER meter indicator should go into the black portion at the left of the scale. If not, adjust R32 and R33 for minimum meter deflection. R32 and R33 are interlocking, and should be adjusted alternately to get the deepest null.

### About That Meter Flicker:

The flickering of the meter pointer is caused by the statistical nature of the noise in the receiver output. Since this flickering is a basic fact of nature, the only way to reduce it (and still make a true SINAD measurement) would be to slow down the meter response time. This response is, in fact, slowed down by C14 in the meter circuit, but further slowing would result in an annoying lag between an adjustment on the radio and the resulting meter indication.

When the SINADDER is used as a receiver alignment aid, the amount of flicker can be greatly reduced by the use of an auxiliary filter circuit (Figure 3) connected between the loudspeaker terminals and the SINADDER test leads. This filter circuit reduces the lower frequency noise components which contribute most of the flicker. When the circuit is in use, however, the SINADDER calibration should be considered only relative, and the circuit should be removed for any quantitative measurements.

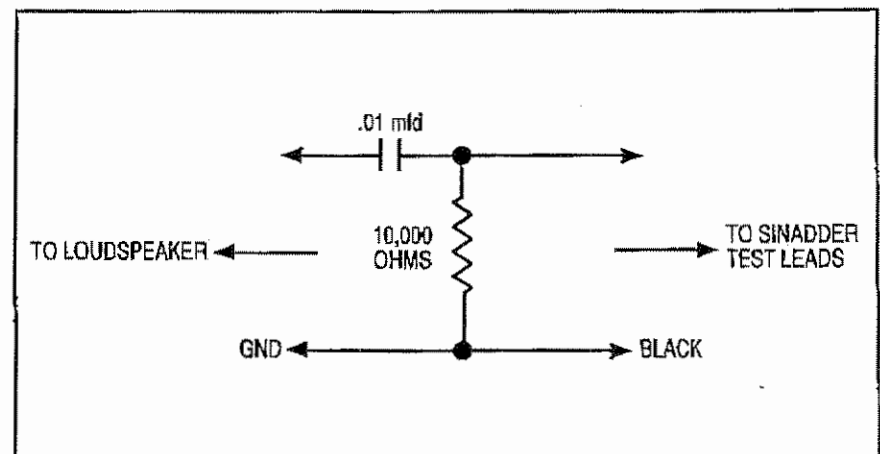

Figure 3. Auxiliary Filter Circuit

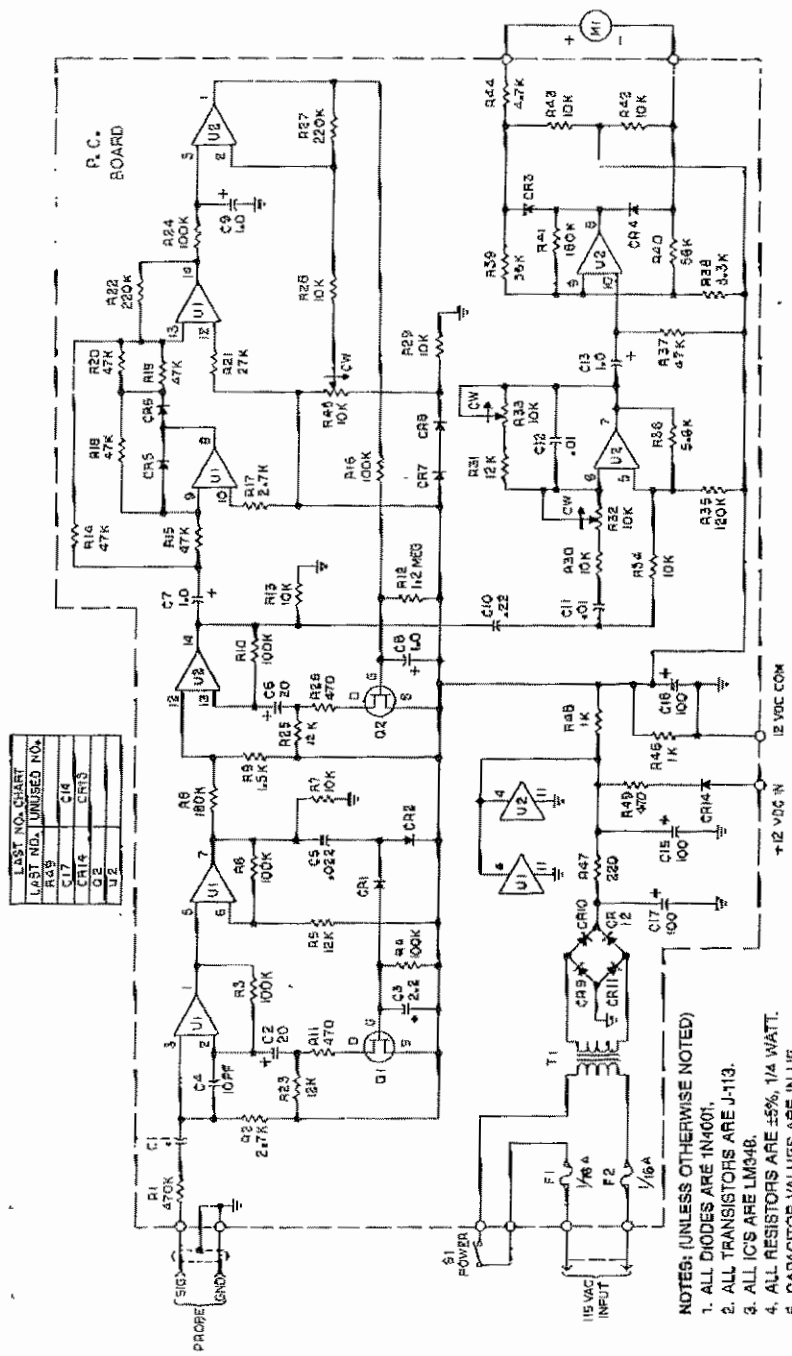
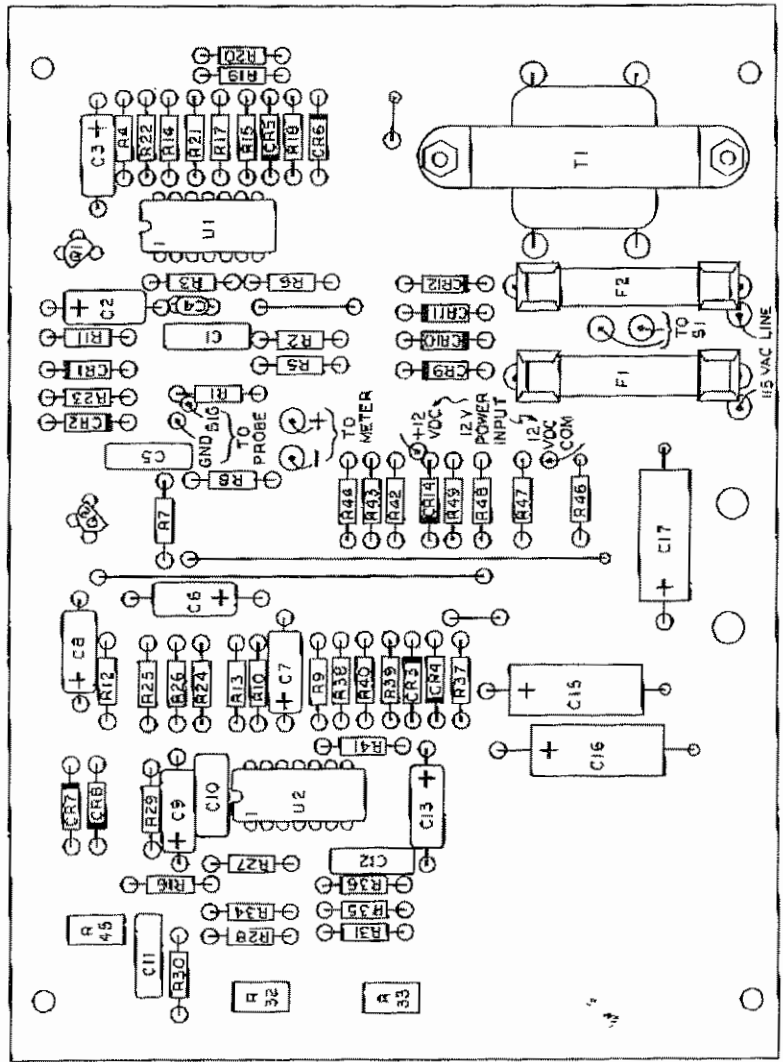

Figure 4. SINADDER™ Schematic Diagram (Revised June 1992)



Note: for DC operation (12-15 VDC), connect the vehicle DC source wires to points indicated in Figure 5 and bring out through the same grommet as the AC cord. Once the modification is made, the SINADDER can be used on 117 volts AC power, or on the 12 volt vehicular system, by simply plugging in the appropriate power leads.

Figure 5. SINADDER™ Circuit Board with Components

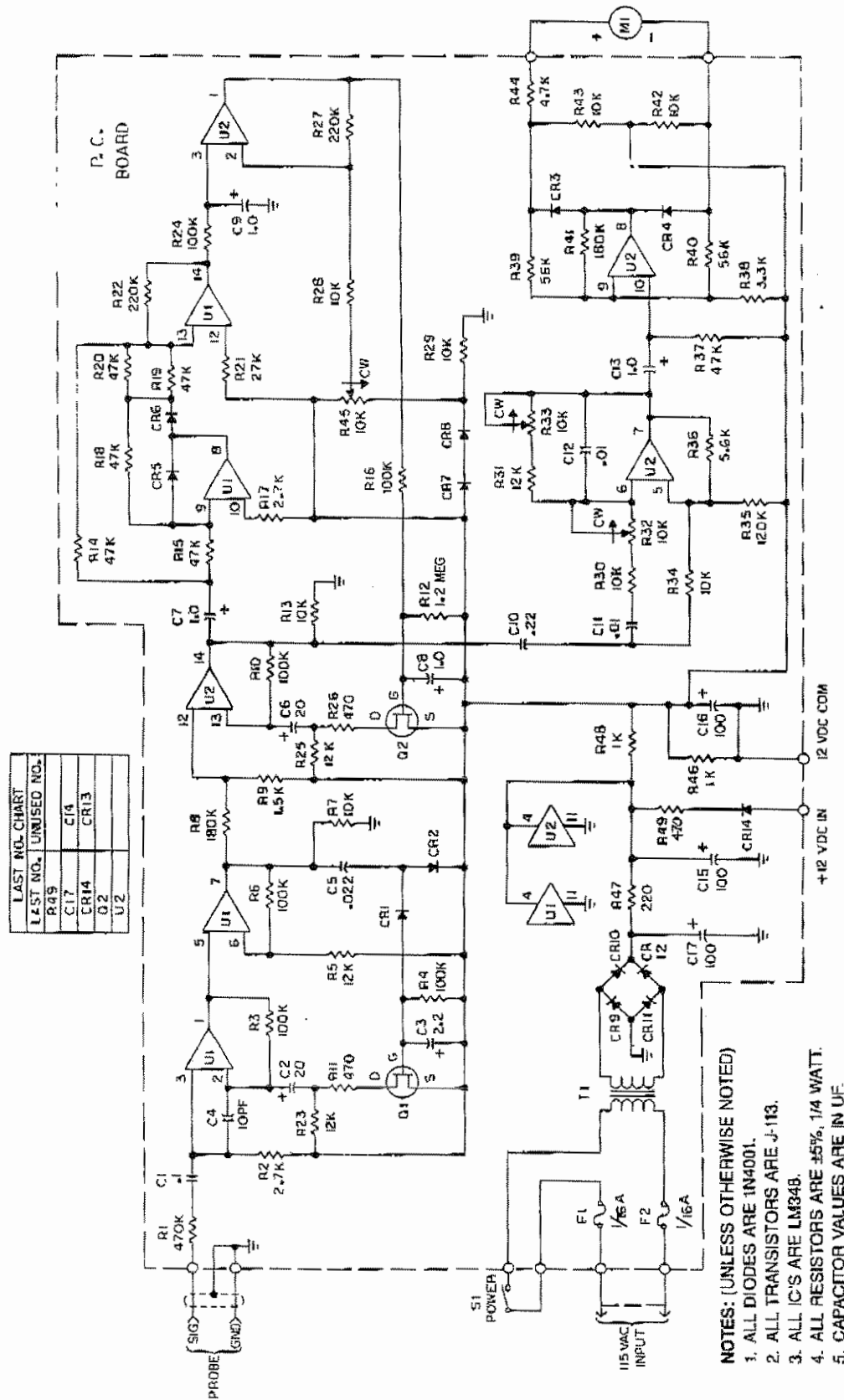

Figure 4. SINADDER™ Schematic Diagram (Revised June 1992)

## HELPER INSTRUMENTS

PRODUCT	ITEM	COMPONENT	DESCRIPTION	UNITS	UM	MEMO
S-101	CIRCUIT BOARD	2.1	S-101 Printed Circuit Board	1	EA	ZB1
S-101	CIRCUIT BOARD	3.004	S-Diode 1N4002 1 Amp	13	EA	CR1-12,14
S-101	CIRCUIT BOARD	3.201	J113 Fet Transistor	2	EA	Q1-2
S-101	CIRCUIT BOARD	3.308	LM340N Quad Op Amp	2	EA	U1-2
S-101	CIRCUIT BOARD	5.002	47 Ohm 1/4 W 5% CF Res	1	EA	R49
S-101	CIRCUIT BOARD	5.01	220 Ohm 1/4 W 5% CF Res	1	EA	R47
S-101	CIRCUIT BOARD	5.011	470 Ohm 1/4 W 5% CF Res	2	EA	R11,26
S-101	CIRCUIT BOARD	5.013	1K 1/4 W 5% CF Res	2	EA	R46,48
S-101	CIRCUIT BOARD	5.014	1.5K 1/4 W 5% CF Res	1	EA	R9
S-101	CIRCUIT BOARD	5.016	2.7K 1/4 W 5% CF Res	2	EA	R2,17
S-101	CIRCUIT BOARD	5.017	3.3K 1/4 W 5% CF Res	1	EA	R38
S-101	CIRCUIT BOARD	5.019	4.7K 1/4 W 5% CF Res	1	EA	R44
S-101	CIRCUIT BOARD	5.02	5.6K 1/4 W 5% CF Res	1	EA	R36
S-101	CIRCUIT BOARD	5.023	10K 1/4 W 5% CF Res	6	EA	R7,13,28-30,34,42-3
S-101	CIRCUIT BOARD	5.024	12K 1/4 W 5% CF Res	4	EA	R5,23,25,31
S-101	CIRCUIT BOARD	5.028	27K 1/4 W 5% CF Res	1	EA	R21
S-101	CIRCUIT BOARD	5.031	47K 1/4 W 5% CF Res	6	EA	R14-5,18-20,37
S-101	CIRCUIT BOARD	5.032	56K 1/4 W 5% CF Res	2	EA	R39-40
S-101	CIRCUIT BOARD	5.035	100K 1/4 W 5% CF Res	6	EA	R3-4,6,10,16,24
S-101	CIRCUIT BOARD	5.036	120K 1/4 W 5% CF Res	1	EA	R35
S-101	CIRCUIT BOARD	5.037	180K 1/4 W 5% CF Res	2	EA	R8,41
S-101	CIRCUIT BOARD	5.038	220K 1/4 W 5% CF Res	2	EA	R22,27
S-101	CIRCUIT BOARD	5.039	470K 1/4 W 5% CF Res	1	EA	R1
S-101	CIRCUIT BOARD	5.043	1.2 Meg 1/4 W 5% CF Res	1	EA	R12
S-101	CIRCUIT BOARD	5.501	10K Trimpot Upright	3	EA	R32-3,45
S-101	CIRCUIT BOARD	7.005	10 PF Cer Disk .2 LS 50V 10%*	1	EA	C4
S-101	CIRCUIT BOARD	7.113	.01 UF Polycarbonate 630V .4LS*	2	EA	C11-2
S-101	CIRCUIT BOARD	7.116	.022 UF E Mylar .4LS 100V 10%*	1	EA	C5
S-101	CIRCUIT BOARD	7.124	.1 UF Polyester .4 LS 250V*	1	EA	C1
S-101	CIRCUIT BOARD	7.128	.22 UF E Metal .4LS 100V 10%*	1	EA	C10
S-101	CIRCUIT BOARD	7.203	1 UF Axial Lytic 50V .25D.5"L"	4	EA	C7-9,13
S-101	CIRCUIT BOARD	7.205	2.2 UF Axial Lytic 35V	1	EA	C3
S-101	CIRCUIT BOARD	7.209	22 UF Axial Lytic 35V Cap	2	EA	C2,6
S-101	CIRCUIT BOARD	7.211	100 UF Axial Lyt 25V 10% Cap	3	EA	C15-7
S-101	CIRCUIT BOARD	10.001	12.6V CT 100 MA Trnsfmr	1	EA	T1
S-101	CIRCUIT BOARD	12.002	14 Pin DIP Socket	2	EA	ZC1
S-101	CIRCUIT BOARD	13.005	Fuse Clip	4	EA	ZC8
S-101	CIRCUIT BOARD	13.002	1/10 Amp Fuse	2	EA	F1
S-101	CHASSIS ASSEMBLY	1.101	S-101 Top Enclosure	1	EA	ZE2
S-101	CHASSIS ASSEMBLY	8.002	SPDT Toggle Switch Flat Handle	1	EA	
S-101	CHASSIS ASSEMBLY	9.001	S-101 Meter	1	EA	M1
S-101	CHASSIS ASSEMBLY	14.001	2 Prong Cordset SPT2 18/2 Blk	1	EA	ZW1
S-101	CHASSIS ASSEMBLY	15.051	6-32 X 3/8 Swage Brass Strndoff	4	EA	ZH4
S-101	CHASSIS ASSEMBLY	15.01	6-32 Hex Nut Steel Zinc	6	EA	ZH1
S-101	CHASSIS ASSEMBLY	15.011	#6 Internal L/W Steel Zinc	2	EA	ZH2
S-101	CHASSIS ASSEMBLY	15.013	6-32 X 1/4 Phil Pan W/S Zinc	10	EA	ZH3
S-101	CHASSIS ASSEMBLY	15.061	4 Small Nylon Tie Wrap*	1	EA	
S-101	CHASSIS ASSEMBLY	16.002	Small Black Rubber Grommet	1	EA	ZH6
S-101	CHASSIS ASSEMBLY	16.003	Large Black Rubber Grommet	1	EA	ZH7
S-101	PACKING & SHIPPING	1.102	S-101 Bottom Cover	1	EA	Z33
S-101	PACKING & SHIPPING	15.053	Grey Bumpen	4	EA	ZH5
S-101	PACKING & SHIPPING	19.005.1	1/2 Bubblepack Non Perforated*	4	FT	
S-101	PACKING & SHIPPING	18.033.4	10 X 8 X 6 Box	1	EA	ZP1
S-101	PACKING & SHIPPING	21.101	S-101 Oper & Service Manual	1	EA	ZM1
S-101	PACKING & SHIPPING	22.101.00	S-101 Serial Number	1	EA	
S-101	PACKING & SHIPPING	TEST LEADS	Test Leads W/Alligator Clips	1	EA	
S-101	PACKING & SHIPPING	21.907	Yellow Warranty Card	1	EA	
S-101	PACKING & SHIPPING	12.023	#10 Spade Lug	2	EA	
S-101	PACKING & SHIPPING	14.401	22 Gauge Buss Wire	11	IN	
S-101	PACKING & SHIPPING	14.503	22 Gauge Green Nabond Wire	6	IN	
S-101	PACKING & SHIPPING	14.51	22 Gauge Yellow Nabond Wire	6	IN	
S-101	PACKING & SHIPPING	14.504	22 Gauge Black Nabond Wire	6	IN	
S-101	PACKING & SHIPPING	14.507	22 Gauge Brown Nabond Wire	6	IN	
S-101	PACKING & SHIPPING	14.203	1/8 Black Shrink Tubing*	1	IN	
S-101	PACKING & SHIPPING	14.201	20 Ga SW Teflon Clear Sleeving	9	IN	
S-101	WIRE	12.023	#10 Spade Lug	2	EA	
S-101	WIRE	14.401	22 Gauge Buss Wire	11	IN	
S-101	WIRE	14.503	22 Gauge Green Nabond Wire	6	IN	
S-101	WIRE	14.51	22 Gauge Yellow Nabond Wire	6	IN	

<u>PRODUCT</u>	<u>ITEM</u>	<u>COMPONENT</u>	<u>DESCRIPTION</u>	<u>UNITS</u>	<u>UM</u>	<u>MEMO</u>
S-101	WIRE	14.504	22 Gauge Black Nabond Wire	6	IN	
S-101	WIRE	14.507	22 Gauge Brown Nabond Wire	6	IN	
S-101	WIRE	14.203	1/8 Black Shrink Tubing*	1	IN	
S-101	WIRE	14.201	20 Ga SW Teflon Clear Sleeving	9	IN	